

International Journal of Water Resources and Environmental Engineering

Volume 6 Number 9 September, 2014

ISSN-2141-6613



*Academic
Journals*

www.academicjournals.org/ijwree

ABOUT IJWREE

The International Journal of Water Resources and Environmental Engineering is published monthly (one volume per year) by Academic Journals.

International Journal of Water Resources and Environmental Engineering (IJWREE) is an open access journal that provides rapid publication (monthly) of articles in all areas of the subject such as waste management, ozone depletion, Kinetic Processes in Materials, strength of building materials, global warming etc. The Journal welcomes the submission of manuscripts that meet the general criteria of significance and scientific excellence. Papers will be published shortly after acceptance. All articles published in IJWREE are peer-reviewed.

Contact Us

Editorial Office: ijwree@academicjournals.org

Help Desk: helpdesk@academicjournals.org

Website: <http://www.academicjournals.org/journal/IJWREE>

Submit manuscript online <http://ms.academicjournals.me/>

Editors

Prof. T. Murugesan

Universiti Teknologi PETRONAS, Malaysia

*Specialization: Chemical Engineering
Malaysia.*

Dr. Sadek Z Kassab

*Mechanical Engineering Department, Faculty of
Engineering, Alexandria University, Alexandria,
Egypt*

*At Present: Visting Professor, Mechanical
Engineering Department, Faculty of Engineering &
Technology, Arab Academy for Science, Technology
& Maritime Transport, Alexandria, Egypt
Specialization: Experimental Fluid Mechanics
Egypt.*

Dr. Minghua Zhou

*College of Environmental Science and Engineering,
Nankai University*

*Specialization: Environmental Engineering (Water
Pollution Control Technologies)
China.*

Dr. Hossam Hamdy Elewa

*National Authority for Remote Sensing and Space
Sciences (NARSS), Cairo, Egypt.*

*Specialization: Hydrogeological and Hydrological
applications of Remote Sensing and GIS
Egypt.*

Dr. Mohamed Mokhtar Mohamed Abdalla

Benha University

*Specialization: Surface & Catalysis
Egypt.*

Dr. Michael Horsfall Jnr

University of Port Harcourt

*Specialization: (chemistry) chemical speciation and
adsorption of heavy metals
Nigeria.*

Engr. Saheeb Ahmed Kayani

*Department of Mechanical Engineering,
College of Electrical and Mechanical Engineering,
National University of Sciences and Technology,
Islamabad,
Pakistan.*

Editorial Board

Prof. Hyo Choi

*Dept. of Atmospheric Environmental Sciences
College of Natural Sciences
Gangneung-Wonju National University Gangneung city,
Gangwondo 210-702*

*Specialization: Numerical forecasting of Rainfall and Flood, Daily hydrological forecasting , Regional & Urban climate modelling -wind, heat, moisture, water
Republic of Korea*

Dr. Adelekan, Babajide A.

*Department of Agricultural Engineering, College of Engineering and Technology, Olabisi Onabanjo
Specialization: Agricultural and Environmental Engineering, Water Resources Engineering, Other Engineering based Water-related fields.
Nigeria*

Dr. Rais Ahmad

*Department of Applied Chemistry
F/O Engineering & Technology
Aligarh Muslim University
specialization: Environmental Chemistry
India*

Dr. Venkata Krishna K. Upadhyayula

*Air Force Research labs, Tyndall AFB, Panama City, FL,
USA
Specialization: Environmental Nanotechnology, Biomaterials, Pathogen
Sensors, Nanomaterials for Water Treatment
Country: USA*

Dr. R. Parthiban

*Sri Venkateswara College of Engineering
Specialization - Environmental Engineering
India*

Dr. Haolin Tang

*State Key Laboratory of Advanced Technology for Materials Synthesis and Processing, Wuhan University of Technology
Specialization: Hydrogen energy, Fuel cell
China*

Dr. Ercument Genc

*Mustafa Kemal University
(Aquaculture Department Chairman, Faculty of Fisheries, Department of Aquaculture, Branch of Fish Diseases, Mustafa Kemal University,31200,Iskenderun, Hatay, Turkey)
Specialization: Environmental (heavy metal), nutritional and hormonal pathologies, Parasitic infections prevalences and their histopathologies in aquatic animals
Turkey*

Dr. Weizhe An

*KLH Engineers, Inc., Pittsburgh, PA, USA.
Specialization: Stormwater management, urban hydrology, watershed modeling, hydrological engineering, GIS application in water resources engineering.
USA*

Dr. T.M.V. Suryanarayana

*Water Resources Engineering and Management Institute, Faculty of Tech. and Engg.,The Maharaja Sayajirao University of Baroda,
Samiala - 391410, Ta. & Dist.:Baroda.
Specialization: Water Resources Engineering & Management, Applications of Soft Computing Techniques
India*

Dr. Hedayat Omidvar

*National Iranian Gas Company
Specialization: Gas Expert
Iran*

Dr. Ta Yeong Wu

*School of Engineering Monash University
Jalan Lagoon Selatan, Bandar Sunway, 46150, Selangor Darul Ehsan
Specialization: Biochemical Engineering; Bioprocess Technology; Cleaner Production; Environmental Engineering; Membrane Technology.
Malaysia.*

International Journal of Water Resources and Environmental Engineering

Table of Contents: Volume 6 Number 9 September 2014

ARTICLES

Research Articles

- | | |
|---|------------|
| Estimate stage-discharge relation for rivers using artificial neural networks- Case study: Dost Bayglu hydrometry station over Qara Su River | 232 |
| Khosro Nezamkhiavy and Sohrab Nezamkhiavy | |
| Assessment of climate change effects on future drought levels by combining a hydrological model and Standardized Precipitation Index (SPI) index in the Nakdong river basin, Korea | 239 |
| Ngo Van Quan and Gwangseob Kim | |

Full Length Research Paper

Estimate stage-discharge relation for rivers using artificial neural networks- Case study: Dost Bayglu hydrometry station over Qara Su River

Khosro Nezamkhiavy* and Sohrab Nezamkhiavy

Young Researchers and Elite Club, Meshkinshahr Branch, Islamic Azad University, Meshkinshahr, Iran.

Received 28 February, 2014; Accepted 22 August, 2014

The prediction of discharge and its variability in a river is an essential component of surface-water planning. For that purpose, a functional relationship between stage and discharge is established with the help of field measurement and the relationship is expressed as a rating curve. Whereas direct discharge measurement in rivers is time consuming and expensive, and sometimes it is impossible, for this purpose the relation between discharge and stage as rating curve is estimated by using of measured data. The Qara Su River in Ardabil province, Iran, makes damages with its floods every year. Informing of flood discharge's value in upstream for management activity in downstream is necessary. In this research for estimate stage-discharge relation in Dost Bayglu hydrometry station over Qara Su River, using MATLAB software, Artificial Neural Network with different state and regression methods studied and finally compared together. As a result of Artificial Neural Network with a 1-2-3-2-1 structure, compared with a simple regression, has a better answer.

Key words: Artificial neural network, stage-discharge relation, Qara Su River, Dost Bayglu hydrometry station, regression.

INTRODUCTION

In hydrometry stations, stage value was usually read while measuring the discharge value of river. At present times engineers read the stage value by advanced devices and send it to the reference centers by using modern methods. If we measure the discharge and the stage value several times, we would find a mathematical relation between them, which was called the stage-discharge relation. Measuring the river discharge constantly, is very difficult and expensive task, even in normal conditions. However, it will be more difficult and sometimes impossible in flood situations or in

unfavorable climate conditions. In some rivers, when there is a reasonable mathematical relation between discharge and stage, we can use stage value, to read and send it to the center, to obtain the discharge value. The stage-discharge relation refers to all possible concepts explaining how to calculate discharge based on measuring the flow parameters. Stage-discharge relation can be defined by determining discharge measuring points and stage parallel points on x and y axis, respectively. Forming of the stage-discharge curve is a function of control station geometry. At the mathematical

*Corresponding author. E-mail: clement2k5@yahoo.com

Author(s) agree that this article remain permanently open access under the terms of the [Creative Commons Attribution License 4.0 International License](https://creativecommons.org/licenses/by/4.0/)

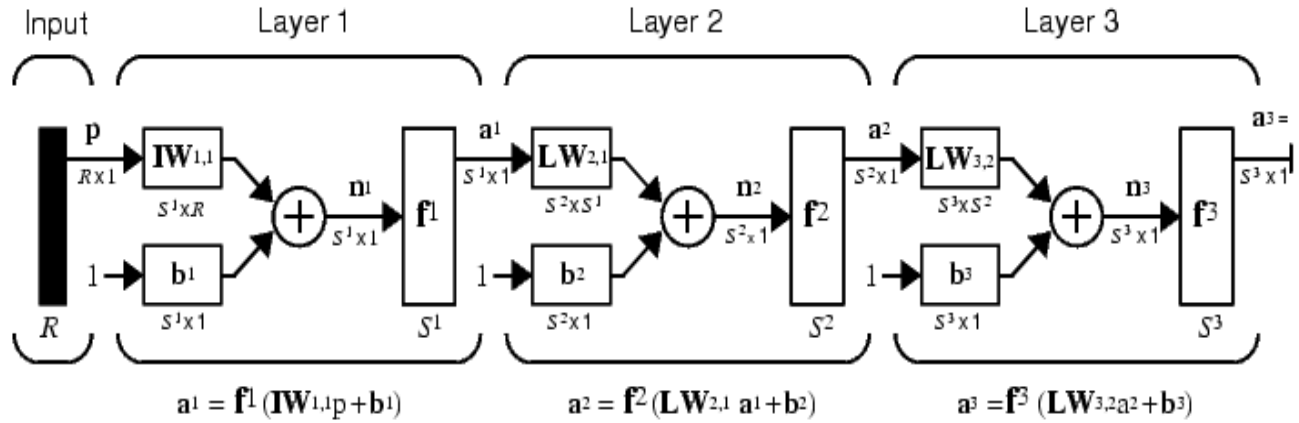

Figure 1. A schema of multiple-layer neural network.

point of view, most of stage- discharge curves haveparabolic form. But, at the regressional point of view, the stage-discharge curves could have various forms such as; polynomial, power, linear and etc.

Goel in his study discussed at the application of soft computing techniques such as back propagation feed forward neural network-based algorithm for modelling stage-discharge relation. The outcome of his study suggests that the back propagation feed forward ANN works quite well for the data sets and produced promising results in comparison to the linear regression technique (Goel, 2011). Bhattacharya and Solomatine (2000) studied the water level and discharge by using 9 years obtained datum from hydrometry station in Bagirathy River, India, by using artificial neural network. The results showed that the power model is the best, as its determination coefficient is about 0.988. Validation test showed that the error in this model is insignificant.

Jain and Chalisgaonkar (2000) studied stage-discharge relation by using artificial neural network in India. In this study, they used three informational layers in artificial neural network model for making stage-discharge curve. The results showed that there is high correlation coefficient in stage-discharge relation by this method.

ANNs are widely used in various areas of water-related research - rainfall-runoff modeling (Minns and Hal, 1996; Dawson and Wilby, 1998), replicating behavior of hydrodynamic modeling systems (Solomatine and Avila Torres, 1996; Dibike et al., 1999), water level control (Lobbrecht and Solomatine, 1999). Muttiah et al. (1997) addressed the problem of discharge prediction, Thirumalaiah and Deo (1998) modeled the stage behavior (without considering discharge). Clair and Ehrman (1996) used ANN to model the relationship between variation of discharge and ecological parameters and climate change. However, extensive search of sources covering the problem of modeling the stage-discharge relationship delivered no result.

METHODOLOGY

In order to perform the research, we collected information and statistics related to discharge-stage on Dost Bayglu hydrometry station, by referring to regional water organization in Ardebil. Then, we analyzed the information and data. By employing simple regression, we obtained the relation between stage and discharge. To do this, in start by dividing data to four parts, we used 3/4 of data as a calibrated data and 1/4 as a validating data.

Artificial neural network (ANN)

Artificial neural network is a simplified model of human brain. The network has mathematical structure able to indicate non-linear, desired, process and compounds, and to find the relation between input and outputs of system. These networks will be used in the future to predict in the future through accomplishing the learning and teaching process.

Neural network consist of neural cells-called neuron, and some communicational units called axon. Neurons are simplified from of biological neurons. Although, the neuron made artificial neural network have higher speed than biological neuron, they have less capability when compared to them. A schema of multiple-layer neural network has been shown in Figure 1. As is shown in Figure 1, each artificial neural network consist of three layers, include: input layer, output layer and hidden layer.

There are some neurons as processor units on each layers, connected to each other by weighted connectors. In this system, errors reach to its least number through conducting some process. To transmit outputs of one layer to another transfer functions were used. Sigmoid, purelin and tan-sigmoid functions are examples of transfer functions. In general, artificial neural network divided to two groups:

- (1) Feed forward networks
- (2) Feed backward networks

Levenberg-Marquardt algorithm (LM)

The research, provide LM algorithm to identify the best method with the highest efficiency for learning network. This algorithm considers one approximation in varying the weights, for Heyzen matrix, like Newton's methods.

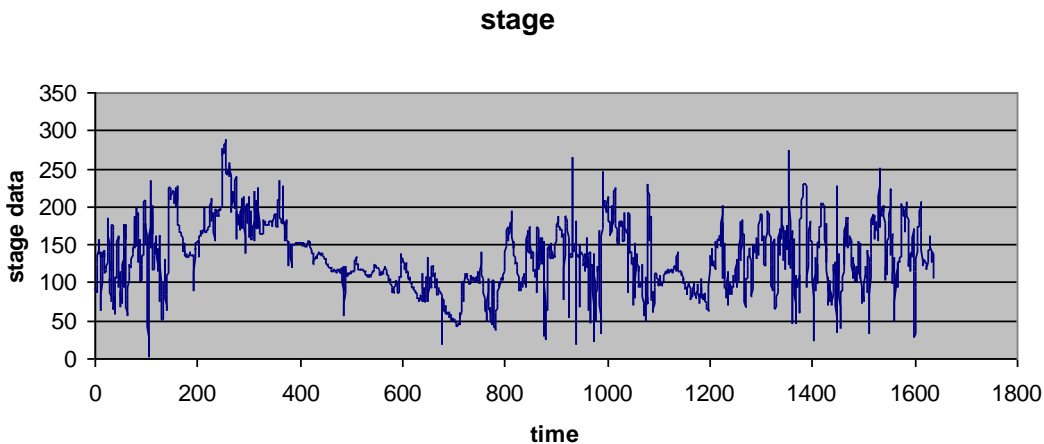

Figure 2. Time series of stage data.

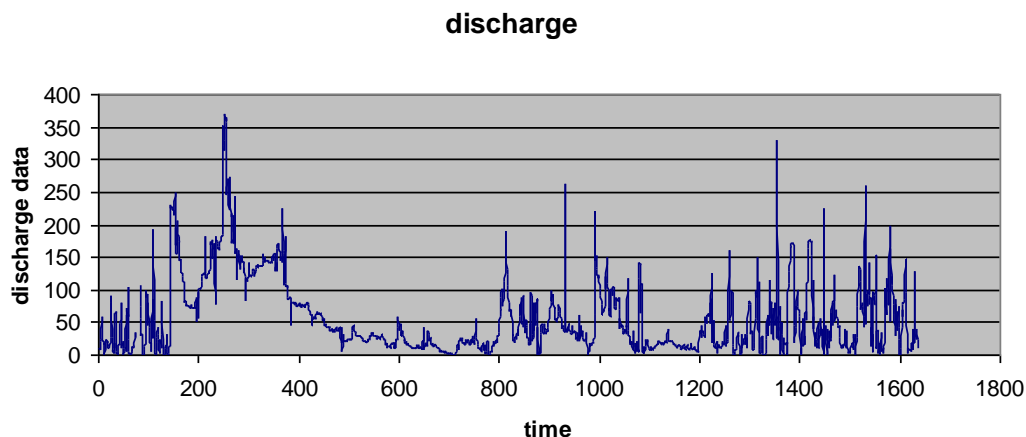

Figure 3. Time series of discharge data.

Specifications of hydrometry station

Qara Su watershed basin is one of the vast in Ardabil province, Iran, its area is about 11126.3 ha. Dost Bayglu hydrometry station established in 1351 and 840 m high from the sea level. It is in 47 – 31 longitude and 38 – 32 latitude. The upstream basin station has area about 7311.1 Km and discharge and stage data are available, until 1384. The station's equipments are: Stage, Limnograph and etc. Normalizing is one of the re-analyzing states for modeling with artificial neural networks. In this research, we used tan-sigmoid transfer function in all layers. So the data should be normalized in respect to transfer function, by following this relation (Figures 2 and 3).

$$x'_i = \frac{x_i - x_{\min}}{x_{\max} - x_{\min}} \tag{1}$$

Model efficiency scale

There are different scales to evaluate the efficiency of the model. In this research, we use Determination coefficient (2), Root Mean Square error (3) and Correlation coefficient (4).

$$R^2 = \frac{\sum_{i=1}^n (Q_i - \bar{Q}_i)^2}{\sum_{i=1}^n (Q_i - \hat{Q}_i)^2} \tag{2}$$

$$RMSE = \frac{\sqrt{\sum_{i=1}^n (Q_i - \hat{Q}_i)^2}}{n} \tag{3}$$

$$CorrCoef = \frac{\sum_{i=1}^n (x_i - \bar{x})(y_i - \bar{y})}{\sqrt{\sum_{i=1}^n (x_i - \bar{x})^2 \sum_{i=1}^n (y_i - \bar{y})^2}} \tag{4}$$

RESULTS

As determination coefficient tended to one, it means

Table 1. The results of modeling by artificial neural network.

Type of neural network	Number of model	input	output	Network structure	logsig				
					Correlation coefficient		R^2		RMSE
					Calibration	Validation	Calibration	Validation	Validation
FFBP	1	Stage data	Discharge data	1-7-12-6-5-1	0.85	0.8	0.81	0.77	0.0043
FFBP	2	Stage data	Discharge data	1-7-12-5-1	0.88	0.84	0.84	0.81	0.0038
FFBP	3	Stage data	Discharge data	1-10-6-1	0.9	0.86	0.87	0.84	0.0033
FFBP	4	Stage data	Discharge data	1-8-5-1	0.94	0.89	0.89	0.85	0.0031
FFBP	5	Stage data	Discharge data	1-2-3-2-1	0.94	0.91	0.9	0.87	0.0028

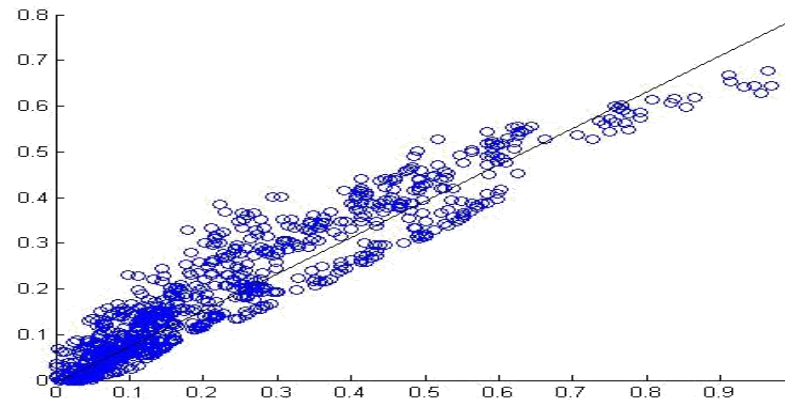

Figure 4. Scatter plot of output number 5- artificial neural network modeling, and observed data- calibration process.

there is more precise relation between stage and discharge. Data have been divided to two parts, calibrated and validating in this method. It have been used 3/4 and 1/4 of data as a calibrated and validating data, respectively, (It means that in this research data consist of 3/4 calibrated data and 1/4 validating data).

In the modeling with artificial neural network for over all models, FFBP method with Levenberg-Marquardt training algorithm (LM) as well as various states of network with different layers was evaluated that results from the best models as shown in Table 1.

Diagrams related to calibration and validation

process of neural network method and, also, time series of predicted and observed data are shown in Figures 5 to 7.

In the modeling with simple regression calibrated data were used in fitting curves. So by applying regression relation on validating data, we obtained the validation correlation coefficient. The

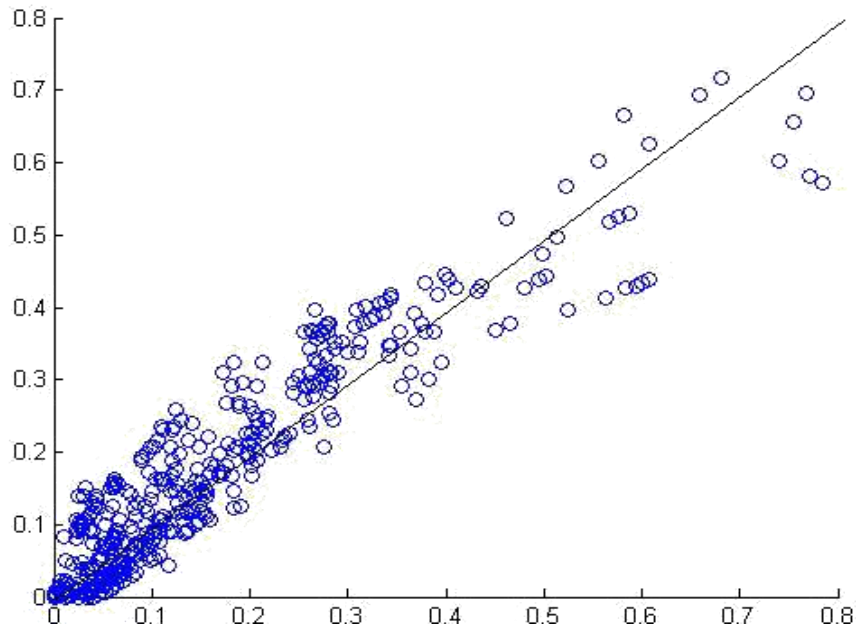

Figure 5. Scatter plot of output number 5- artificial neural network modeling, and observed data- validation process.

time series

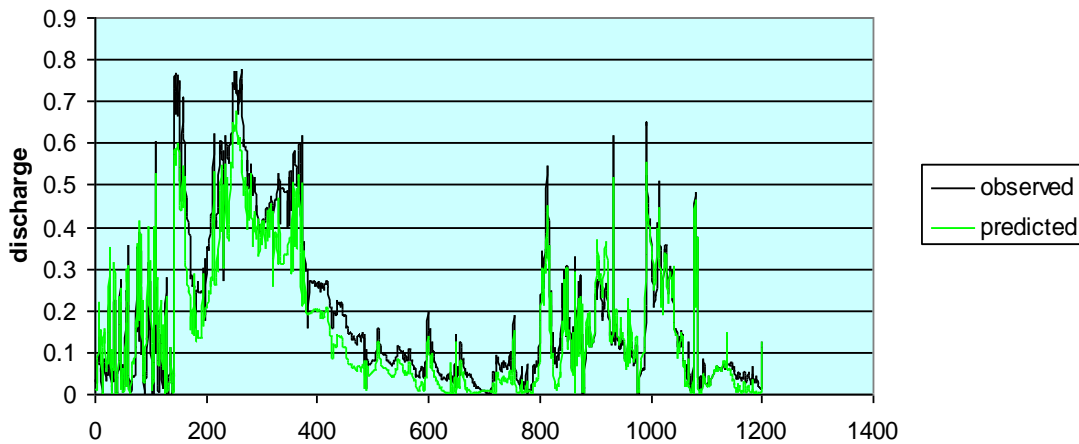

Figure 6. Time series of output number 5- artificial neural network modeling, and observed data- calibration process.

evaluation process was applied on curves and functions then, they were selected based on having the favorable determination coefficient. In this research, polynomial curve provide the best result for Dost Bayglu station. Validation and calibration correlations coefficients are shown in Table 2. Diagrams related to calibration and validation process of this method and, also, time series of predicted and observed data are shown in Figures 8 to 10.

DISCUSSION

It is finally concluded that in artificial neural network (FFBP Network with LM training algorithm), stage data as input and discharge data as output with a 1-2-3-2-1 structure with determination coefficient of 0.87 as the best model has been introduced (Table 3). It is observed that the ability of artificial neural network for stage-discharge modeling is better than other evaluated method

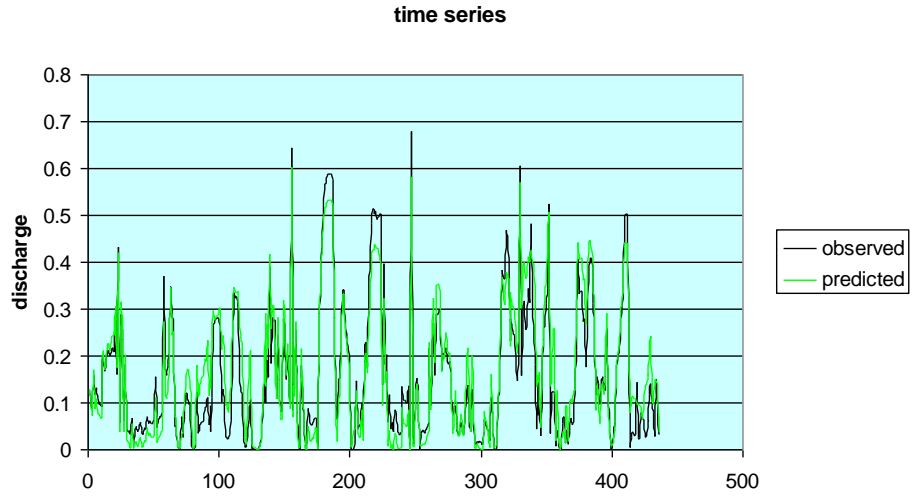

Figure 7. Time series of output number 5- artificial neural network modeling, and observed data- validation process.

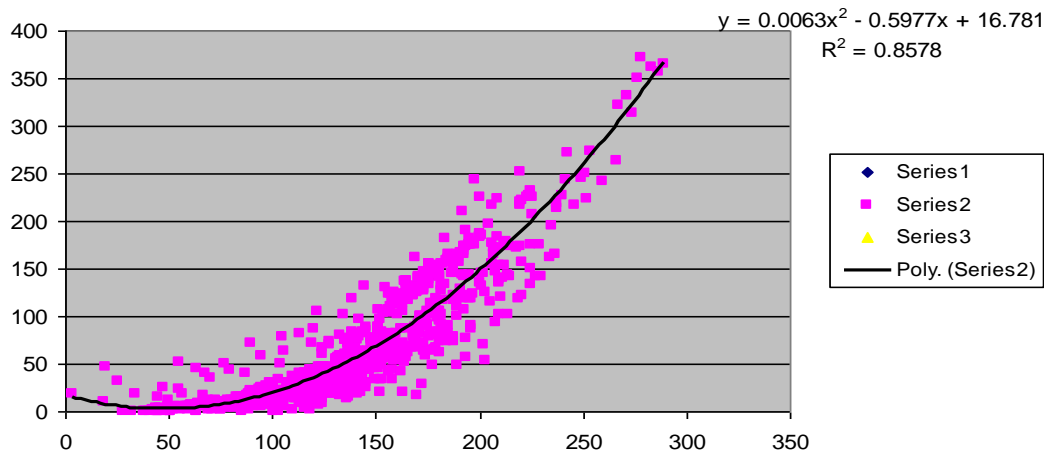

Figure 8. Rating curve - calibration process.

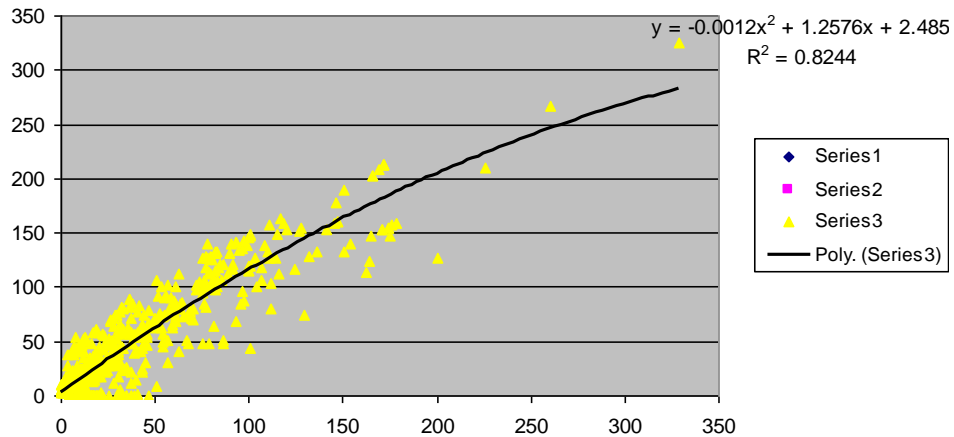

Figure 9. Rating curve - validation process.

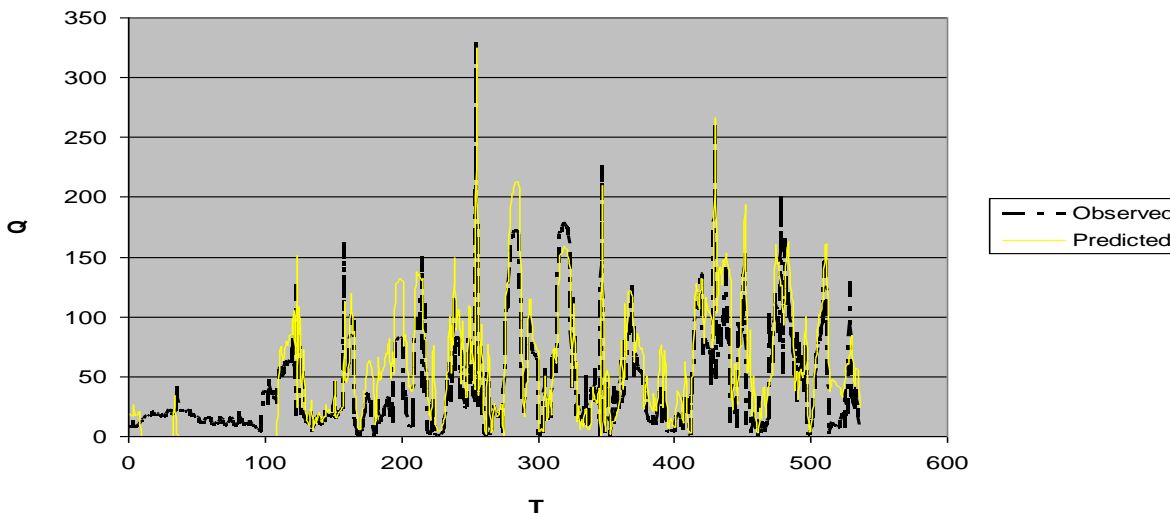

Figure 10. Time series of predicted and observed data.

Table 2. The results of modeling by simple regression.

Model	Calibration correlation coefficient	Validation correlation coefficient
Rating curve	0.85	0.82

Table 3. Comparison between results of modeling.

Modeling	Number of model	Structure	Calibration determination coefficient (R^2)	Validation determination coefficient (R^2)
Artificial neural network (ANN)	3	2-3-1	0.90	0.87
Rating curve	-		0.85	0.82

in this research (simple regression).

Conflict of Interest

The authors have not declared any conflict of interest.

REFERENCES

Alizadeh A (2002). Principles of applied hydrology. 16th edition. Emam Reza university, Mashhad.
 Bhattacharya B, Solomatine DP (2000). Application of artificial neural network in stage-discharge relationship. 4th International Conference on Hydroinformatics, Iowa City, USA.
 Goel A (2011). ANN-Based Approach for Predicting Rating Curve of an Indian River. International Scholarly Research Network, ISRN Civil Engineering Volume 2011, Article ID 291370, 4 pages doi:10.5402/2011/291370 <http://dx.doi.org/10.5402/2011/291370>
 Lohani AK, Goel NK, Bhatia KKS (2007). Deriving stage-discharge-sediment concentration relationships using fuzzy logic. Hydrol. Sci. J. 52(4):793-807. <http://dx.doi.org/10.1623/hysj.52.4.793>

Jain SK, Chalisgaonkar (2000). Setting up stage-discharge relations using ANN. J. Hydrol. Eng. 5(4):428-433. [http://dx.doi.org/10.1061/\(ASCE\)1084-0699\(2000\)5:4\(428\)](http://dx.doi.org/10.1061/(ASCE)1084-0699(2000)5:4(428))
 Thirumalaiah K, Deo MC (1998). River stage forecasting using artificial neural networks. J. Hydrol. Eng. 9(1):26-32. [http://dx.doi.org/10.1061/\(ASCE\)1084-0699\(1998\)3:1\(26\)](http://dx.doi.org/10.1061/(ASCE)1084-0699(1998)3:1(26)).

Full Length Research Paper

Assessment of climate change effects on future drought levels by combining a hydrological model and Standardized Precipitation Index (SPI) index in the Nakdong river basin, Korea

Ngo Van Quan^{1*} and Gwangseob Kim²

¹Department of Water Resources Engineering, Water Resource University, 175 Tay Son street, Dong Da district, Hanoi Vietnam.

²Department of Civil Engineering, Kyungpook National University, Sankyuk-Dong, Buk-Gu, Daegu, 702-701, South Korea.

Received 31 March, 2014; Accepted 28 August, 2014

The main purpose of this study is to analyze the effects of climate change on drought levels in the future by using both hydrological model (SWAT) and Standardized Precipitation Index (SPI) tools. Three benchmark periods of climate change were used for simulation such as 2010-2039, 2040-2069 and 2070-2099. These results were then compared with the baseline period (1980-2009) at nine zones in the basin. Results indicated that both the SWAT model and SPI index showed a similar correlation in duration and density of the drought occurrence levels based on shortage of soil water content and values of drought index through climate change effects. These impacts include not only temporal changes, but also spatial changes, in the future. Results also reflect that the soil water shortage and values of SPI index also showed significant reductions in April, May and November. Most of the severe droughts seem to increase in intensity in two of these months, specifically those that appeared in April in five sub-basins and in November in six sub-basins during the period of 2010-2039; drought in April appeared in four sub-basins and drought in November in six sub-basins in the period of 2040-2069; severe drought occurred in nine sub-basins in April and seven sub-basins in November during the period of 2070-2099. The results suggest that the drought occurrence levels have a trend of increased severity from the North to the South and gradually reduced from the East to the West in May, but then the drought severity increased in the middle of basin with the trend from the South to the North in November. The methods applied in this study are expected to be appropriately applicable to the evaluation of the effects of extreme hydrologic events, and this study can provide useful values for sustainable water-resource management strategies and policy in agricultural basins.

Key words: Hydrology model, standardized precipitation index, climate change, soil water content drought levels.

INTRODUCTION

Climate change has not only significantly influenced hydrologic processes during the last decades but will

continue to influence processes more extremely in the future in river basins. Its impacts have affected the supply

and management of water resources, especially its strong influences on disaster as floods and drought in watersheds. Several recent articles highlight concerns over climate change and changing precipitation patterns that can be particularly damaging (IPCC, 2007). In fact, drought is estimated to be the most costly natural disaster in the world (Witt, 1997). The wide range of detrimental effects associated with precipitation deficits include: Decreased crop yields, increased wildfires, death of cattle and wildlife, water shortages, and rising food prices (Witt, 1997). The estimation of direct and indirect damages makes it difficult to enumerate the exact costs, although the Federal Emergency Management Agency estimates losses on average of about US\$6–8 billion in damages annually in the United States alone (Witt, 1997). Moreover, consequences of drought have long plagued ecosystems and society (Le Roy Ladurie, 1971). The consequences of drought vary greatly depending on its location, timing, extent and the type of society or societal sector impacted by the drought (Gleick, 1993). Such temporary anomaly conditions can be well represented in a number of ways by evaluating anomalous water supply (precipitation) conditions, or through other variables such as soil moisture conditions. The combination of what defines a drought that has an impact on a particular sector of society and the choice of variables to use to define drought led to over 150 definitions of drought (Wilhite and Glantz, 1985). Recognizing that set precipitation amounts could not define drought conditions, since drought period attempted to distinguish between locations that observe “permanent drought,” The consequences of drought vary greatly by the length and timing of the precipitation deficit, which is often not taken into account in the interpretation of model results. More recently, Heim (2002) divides drought into four categories based on the myriad of effects meteorological, agricultural, hydrological, and socioeconomic. Meteorological drought simply refers to the atmospheric conditions that result in the absence or reduction of precipitation. Because its definition only relies on rainfall, meteorological drought can end literally overnight, as soon as sufficient precipitation falls to bring levels close to average. Agricultural drought is a short-term dryness in soil layers that can reduce crop yields. Due to its reliance on plant and soil conditions, agricultural drought usually has a lag time in response to precipitation changes (Park et al., 2005), and the impact depends greatly on the timing of the drought in relation to crop growth. Hydrological droughts have an even longer lag time, as they are defined by deficiencies in surface and subsurface water supplies, which respond more slowly to meteorological conditions.

Similarly to other countries in the world, the river basins

of Korea are influenced by climate change. According to the Intergovernmental Panel on Climate Change's (IPCC, 2007) findings, developing countries like Korea will be more vulnerable from climate change. On the other hand, Korea is located in the southeastern region of the Asian Monsoon region that shows a typical seasonal pattern in its climate. Four seasons are developed due to the temperature and rainfall amount. Over 60% of the total annual precipitation is concentrated in the wet summer season, so flooding has become an annual event in the Korean Peninsula. The monsoon lasts about a month from mid-June to July, and several typhoons hit the Korean peninsula from late August to September. Convective storms also frequently develop locally to cause flash floods (Han and Byun, 1994), while the dry season is a long dry spell that continues until the monsoon season begins in spring, autumn, and winter. Therefore, drought events are inevitable in Korea in general and in particular in the Nakdong river basin. However, in contrast to floods, it is difficult to know when a drought begins and it is also difficult to determine when a drought is over and according to what criteria this determination should be made. There were many researches considering quantifying drought, most of which have been based on precipitation data analysis (Byun, 1996; Kyung et al., 2007), Drought analysis under climate current and future precipitation data (Karavitis, 2011). Although it is true that these attempts helped quantifying drought to some extent, it is expected that future climate changes as a result of increasing greenhouse gases will affect temperature or evaporation and precipitation patterns in Nakdong river basin and thus hydrologic moisture conditions will be changed. In particular, since agricultural productivity is greatly dependent on the amount of water supplied in the form of soil water, the understanding of soil water and grasping the form of its future changes become very meaningful when measures to adapt to climate changes are prepared. Therefore, it will become very difficult to compare droughts that will occur in the future with present droughts with only the analysis of precipitation data. Droughts can be said to be cases in which the amount of water going out is larger than the amount of water coming into the basin compared to ordinary times. In short, droughts can be represented by precipitation (the amount of water coming in) and the amount of evaporation (the amount of water being lost). If temperature patterns are assumed to be the same in the future too, droughts in the future can be sufficiently compared with present droughts using only the analysis of data on precipitation expected to occur in the future. However, future climates in basins in Korea predicted from several global climate models affect temperature

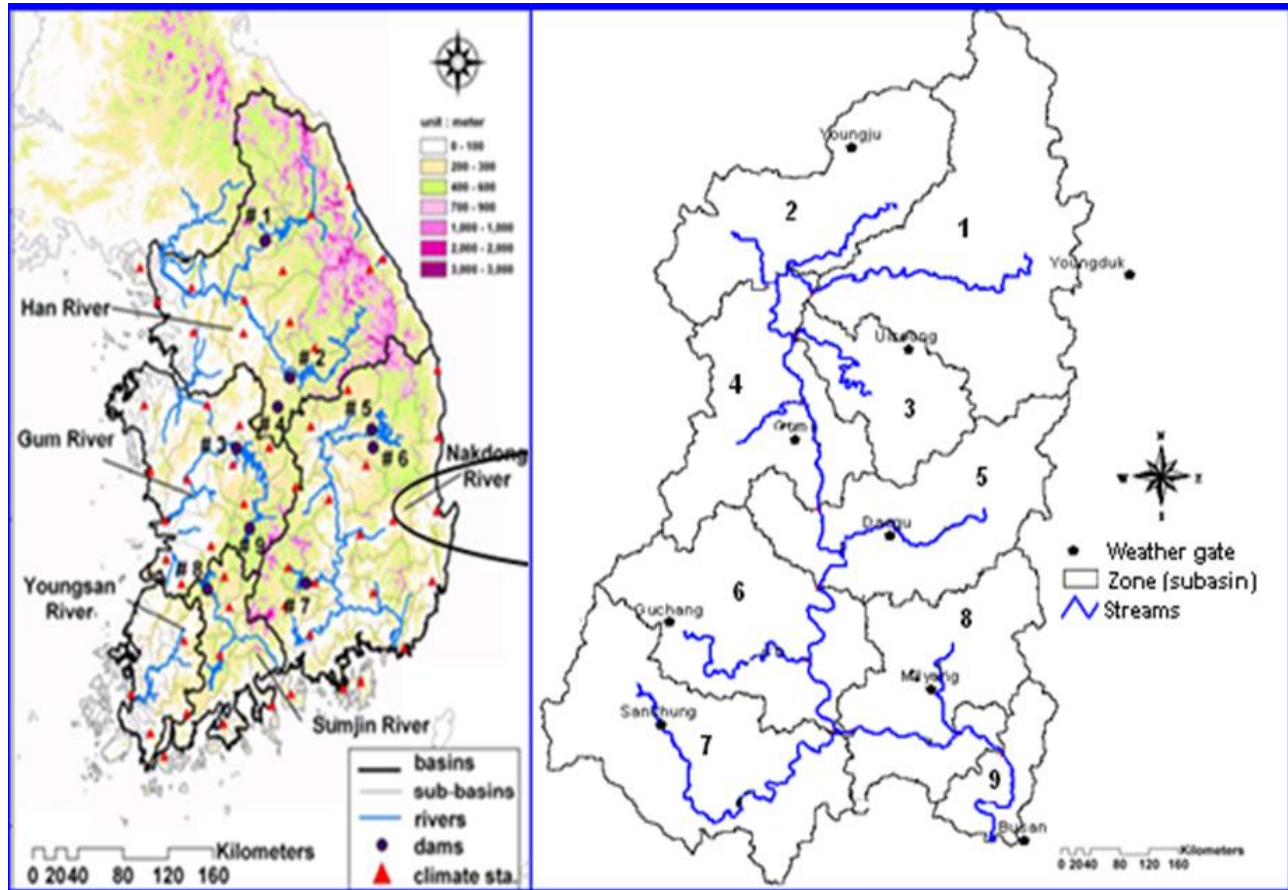

Figure 1. Location of study area, river systems.

increases (+3.2°C) or evaporation increases (+25%) more strongly than changes in precipitation (+9.3%) by the 2080s (Bae et al., 2011). Therefore, it can be said that, to predict droughts in the future, droughts should be analyzed considering not only changes in precipitation, but also temperature or evaporation increases. One of the hydrological components that best reflects changes in temperatures and precipitation should be soil water. Soil water is a hydrological component that serves the role of a link in the hydrologic cycle of precipitation-infiltration-runoff-evapotranspiration and it is perceived as a very important hydrologic component in hydrologic evaluation of climate changes because it is located in the intermediate layer that connects the earth surface with the atmosphere. On the other hand, the importance for considering the present study area is because of the following reasons: (a) The basin is situated in an underdeveloped part of the Nakdong basin, so no study was conducted earlier for drought analysis; (b) The people in the region mostly depend on agriculture, so it is very important to analyze drought in the basin; and (c) The basin was affected by severe droughts in recent years. Therefore, it was necessary for the researchers to investigate drought in the basin. In order to achieve the

purpose of this study, both a hydrology model and drought index analysis were combined to assess effects of climate change on drought occurrence in the Nakdong river basin.

Study area and data description

The Nakdong river basin is one of the biggest basins in South Korea, located in the monsoon region (35-37° N, 127-129° E) (Figure 1). This region is characterized by heavy rainfall in the monsoon season in early summer from Middle June to August.

The river drains an area of 23,817 km² and the length of the main stream is over 525 km. The annual mean precipitation across the river basin is about 1200 mm, but more than 60% of the annual rainfall is concentrated during the summer season (June-August). The mean air temperature is 2.2°C during the coldest month (January) and 25.9°C in the warmest month (August). The Nakdong River basin is an important water resource for the southeastern area with about 7 million people residing within the basin and more than 13 million people taking drinking-water from the river. In particular, the large

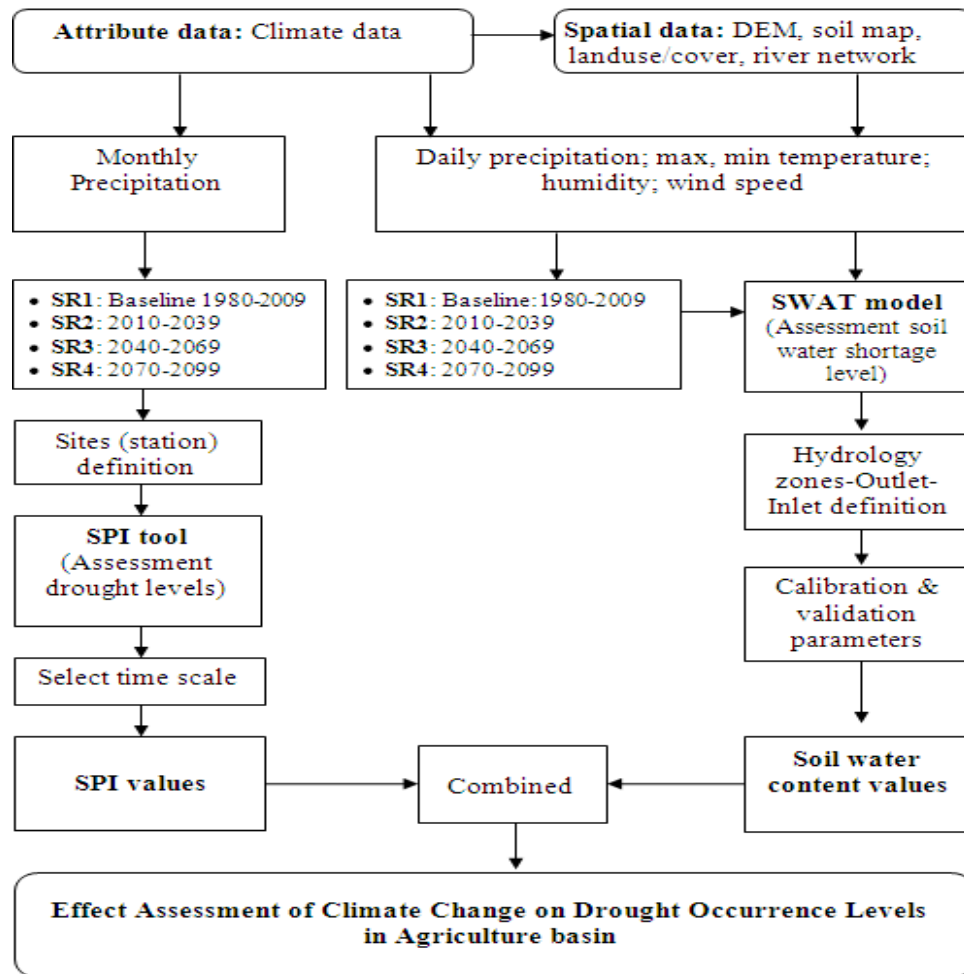

Figure 2. The flow chart of study.

amount of water demand for agricultural productivity is greatly dependent on the amount of water supplied and the cause of the water shortage in the region.

In this study, the data that were collected for both hydrological and land-use models were used in clued spatial data and time series. Spatial data include a Digital Elevation Model (DEM), a digital layer of land use/land cover, a soil map and a river system layer. Time series data include the current climate data from 1980 to 2009 and future climate change for the period 2010-2099, which included daily data of precipitation, maximum and minimum temperature, solar radiation, humidity, and wind speed and direction for fourteen weather stations. Hydrology data included monthly flow for the period of 1995-2009 around Nakdong basin stations. All of the data sources were collected by Korea Meteorological Administration (KMA) and the Water Management Information System (WAMIS), which was built for providing services including scientifically collecting, creating, and processing water-resource information.

This study of climate change is based on available

climate-change data. Specifically, the data were used from the GCM output under three different emission scenarios (A2, B1, A1B) for the period of 2010-2099. In these scenarios, A2 was generated with high emission scenario and it represents a realistic worst case for climate change in Korea. Therefore, A2 scenario was selected to use in this study. On the other hand, in order to assist in comparison and assessment, as well as identification of average change in the future periods relative to the past 30-year observed baseline period of 1980-2010, the future long period was divided into three periods of 2010-2039, 2040-2069 and 2070-2099.

METHODS AND MATERIALS

Figure 2 shows the flow chart of the study methods for evaluating the effect of climate change on drought levels using both the hydrology model and Standardized Precipitation Index methods. It involves these steps: Firstly, in order to simulate the deficiency of soil water content, the Soil and Water Assessment Tool (SWAT) hydrologic model was set up. The data input into SWAT model

include: Time-series (climate data), and spatial data (DEM, Landuse/land cover, soil map). In this study, the climate is change in the future, but the landuse/land cover is unchanged (as constant), and the landuse/land cover in 2000 year is used in this study, then calibrated and validated with periods of 1995-2004, respectively. Then, the SWAT model was run for climate change for three different periods (2010-2039, 2040-2069 and 2070-2099) and the baseline period (1980-2010) to simulate the soil water content in different hydrology zones (Figure 1) in the study area. Secondly, the Standardized Precipitation Index (SPI), which is based on the cumulative probability of a given rainfall event occurring at a station, was used to determine the rarity of a drought in a sub-basin in the study area. Finally, the impacts of climate change on soil water content were quantified by comparing the SWAT output for the different periods of 2010-2039, 2040-2069 and 2070-2099 with the results of simulations of the present state as of 1980-2009. In addition, a combination of the Standardized Precipitation Index (SPI) was used for describing and comparing with correlation to assess drought occurrence with different climatic conditions. In order to assist in assessment, the four scenarios were assigned to different periods of Scenario 1 (SR1): Current climate (1980-2009); Scenario 2 (SR2): Future climate period (2010-2039); Scenario 3 (SR3): Future climate period (2040-2069); Scenario 4 (SR4): Future climate period (2070-2099), and the effect of climate change on the drought levels in the future were compared between future periods with the observed period.

Hydrology model

The SWAT model was used in this study to evaluate the impacts of climate changes on soil water in the Nakdong River basin. SWAT is in the domain of semi-distributed hydrological models. It is a physically based, basin scale, continuous time model. SWAT integrates more than 30 years of model development within the US Department of Agriculture’s (USDA) Agricultural Research Service (ARS) into a single model, developed to support water managers in forecasting and assessing the impacts of climate and land use management practices on water supplies, sediment, non-point source loadings, and pesticide contamination in ungauged watersheds and large, complex river basins with varying soils, land use and management conditions over long periods of time (Arnold et al., 1998; Neitsch et al., 2005a). Upland model components in the latest version include weather, hydrology, erosion, sedimentation, soil temperature, plant growth, nutrients, pesticides, agricultural management, sediment and nutrient loadings from urban areas, and bacteria growth. Stream processes allow for routing of water, sediment, nutrients and organic chemicals in the main channel and transport of bacteria from land areas to the stream network.

The hydrologic cycle is based on the water balance equation:

$$SW_t = SW_0 + \sum_{i=1}^t (R_{day} - Q_{surf} - E_a - W_{deep} - Q_{gw}) \quad (1)$$

where SW_t is the final soil water content (mm H₂O), SW_0 is the initial soil water content on day i (mm H₂O), t is time (days), R_{day} is the amount of precipitation on day i (mm H₂O), Q_{surf} is the amount of surface runoff on day i (mm H₂O), E_a is the amount of evapotranspiration on day i (mm H₂O), W_{deep} is the amount of water into the deep aquifer on day i (mm H₂O), and Q_{gw} is the amount of return flow on day i (mm H₂O). One of the major features of SWAT is its partitioning of the study basin into sub-basins that are connected by surface flows (Neitsch et al., 2005b). Each sub-basin (Figure 1) is further divided into one or more hydrological response units (HRU) according to topography, types of land-use, and soil. In each HRU, hydrological components of the water

budget for surface water, soil water content, and groundwater are calculated. In these calculations, precipitation is assumed to be intercepted by the canopy of vegetation. The amount of water held by the canopy is a function of the density of plant cover and the morphology of plant species defined by the leaf area index. Precipitation reaching the ground after interception infiltrates into soils. The infiltration rate varies according to soil water content (Neitsch et al., 2005b). In the root zone, percolation occurs when the root zone is saturated. Percolation continues to deliver soil water to the aquifer, which is very important to know the water in soil. Evapotranspiration (ET) is the primary mechanism of surface and soil water loss for HRUs. The method developed by Ritchie (1972) was used to calculate actual ET. Potential ET is available in model and it can be selected or the Penman-Monteith or Priestley-Taylor method. Runoff was predicted separately for each hydrologic response unit (HRU) and routed to obtain the total runoff for the watershed.

The standardized precipitation index

SPI is a tool that was developed primarily for defining and monitoring drought. It allows an analyst to determine the rarity of a drought at a given time scale (temporal resolution) of interest for any rainfall station data. It can also be used to determine periods of anomalously wet events. Mathematically, the SPI is based on the cumulative probability of a given rainfall event occurring at a station. The historic rainfall data of the station is fitted to a gamma distribution, as the gamma distribution has been found to fit the precipitation distribution quite well. This is done through a process of maximum likelihood estimation of the gamma distribution parameters, α and β . In simple terms, the process described above allows the rainfall distribution at the station to be effectively represented by a mathematical cumulative probability function. Therefore, based on the rainfall data, an analyst can then tell what is the probability of the rainfall which is less than or equal to a certain amount. Thus, the probability of rainfall being less than or equal to the average rainfall for that area will be about 0.5, while the probability of rainfall being less than or equal to an amount much smaller than the average will be lower (0.2, 0.1, 0.0,1 etc., depending on the amount). Therefore, if a particular rainfall event has a low probability on the cumulative probability function, then this is indicative of a likely drought event. Alternatively, a rainfall event which has a high probability on the cumulative probability function is an anomalously wet event. Moreover, the SPI can effectively represent the amount of rainfall over a given time scale, with the advantage that it provides not only information on the amount of rainfall but also gives an indication of what this amount is in relation to the normal level, thus leading to the definition of whether a station is experiencing drought or not. Drought classification levels based on SPI are shown in Table 1. The SPI method is computed by fitting a probability density function to the frequency distribution of precipitation summed over the time scale of interest. The SPI was developed by McKee et al. (1993, 1995) with the purpose of identifying and monitoring local droughts. This is performed separately for each month and for each location in space. Each probability density functions are then transformed into a standardized normal distribution. The gamma distribution is defined by its probability density function as given in Equation (1):

$$g(x) = \frac{1}{\beta^\alpha \Gamma(\alpha)} x^{\alpha-1} e^{-x/\beta} \quad \text{for } x > 0 \quad (2)$$

Where: $\alpha > 0$ is a shape factor, $\beta > 0$ is a scale factor, and $x > 0$ is the amount of precipitation. $\Gamma(\alpha)$ is the gamma function. The resulting parameters are then used to find the cumulative probability of an observed precipitation event for the given month or any other time

Table 1. Drought classification levels based on SPI index.

SPI Values	Drought levels
2.0+	Extremely wet
1.5 to 1.99	Very wet
1.0 to 1.49	Moderately wet
-0.99 to 0.99	Near normal
-1.0 to -1.49	Moderately dry
-1.5 to -1.99	Severely dry
-2 and less	Extremely dry

scale using Equation (2):

$$G(x) = \int_0^x g(x)dx \quad (3)$$

Since the gamma function is undefined for $x=0$ and a precipitation distribution may contain zeros, the cumulative probability becomes as given in Equation (3):

$$H(x) = u + (1-u)G(x) \quad (4)$$

Where: u is the probability of zero precipitation. The cumulative probability, $H(x)$ is then transformed to the standard normal random variable Z with a mean of zero and a variance of one, which is the value of SPI as shown in Equations (4) and (5):

$$Z = SPI = - \left(k - \frac{c_0 + c_1 k + c_2 k^2}{1 + d_1 + d_2 k^2 + d_3 k^3} \right) \quad \text{for } 0 < H(x) \leq 0.5 \quad (5)$$

$$Z = SPI = + \left(k - \frac{c_0 + c_1 k + c_2 k^2}{1 + d_1 + d_2 k^2 + d_3 k^3} \right) \quad \text{for } 0 < H(x) \leq 0.5 \quad (6)$$

Where:

$$k = \sqrt{\ln\left(\frac{1}{H(x)^2}\right)} \quad \text{for } 0 < H(x) \leq 0.5$$

$$k = \sqrt{\ln\left(\frac{1}{1-H(x)^2}\right)} \quad \text{for } 0.5 < H(x) < 1$$

and $c_0=2.515517$, $c_1=0.802853$, $c_2=0.010328$, $d_1=1.432788$, $d_2=0.189269$, $d_3=0.001308$

Where the positive SPI values indicate the rainfall is greater than median rainfall and negative values indicate less than median rainfall. Dry conditions are defined by $0.00 < SPI < -0.99$, moderately dry by $-1.00 < SPI < -1.49$, severely dry by $-1.5 < SPI < -1.99$, and extremely dry by $SPI < -2.00$. A drought event starts when the SPI value reaches -1.00 and ends when SPI becomes positive again.

Based on the SWAT model, nine sub-basins were determined for the study area (Figure 3), and the SPI time series were computed for different periods for all sub-basins.

RESULTS

In this study, the data for calibrating and validating are streamflow at the two stations of Goengwan and

Jindong in the Nakdong river basin. The SWAT model was used to calibrate against measured streamflow for a period of ten years (1995-2004) and validate by a period of five years (2005-2009). The sensitive parameters for the streamflow calibration were CN2 (the curve number); ESCO (soil evaporation compensation factor); GW_REVAP (groundwater revap coefficient); ALPHA_BF (base flow alpha factor); CH_K2 (channel hydraulic conductivity); TLAPS (temperature lapse rate) and SOL_AWC (soil available water content). These parameters were adjusted from SWAT initial parameters until acceptable matching of the simulated and observed flow. Calibration parameters for various model outputs were constrained within the range and final calibration values are shown in Table 2. Then the regression statistical parameters of Nash-Sutcliffe coefficient of efficiency (E_{NS}) (Santhi et al., 2001) and the coefficient of determination (R^2) were used to measure the model performance. In the validation process, the model is operated with input parameters set during the calibration process without any change and the results are compared to the remaining observation to evaluate the model prediction. The simulated monthly streamflow was compared with the observed streamflow values for calibration at Goengwan and Jindong stations. The results show good consistency between the simulated and measured monthly streamflow for two stations according to regression statistical parameters. The regression statistical parameters show that the validation period statistics were stronger than those computed for the calibration period for both stations, with $R^2 = 0.92$ and $E_{NS} = 0.81$ in the validation period versus corresponding values of 0.94 and 0.86 for the calibration period Goengwan station and $R^2 = 0.90$ and $E_{NS} = 0.78$ versus corresponding values of 0.92 and 0.83 for the calibration period at Jindong station. The detailed results are given in Table 3.

Climate change impact on soil water content

In this study, the result was simulated for nine of sub-basins (zones) (Figure 1). However, to order to advantage in the analysis and assessment the result were shown representative figures for four sub-basins as

Table 2. The calibrated parameters for SWAT at Goeangwan and Jindong stations.

Calibration parameter	Name	SIM1	Range values	Calibrated values of Goeangwan station	Calibrated values of Jindong station
		Default		Final	Final
Curve number for moisture condition II	CN2	Default	±25%	+20%	+20%
Soil evaporation compensation factor	ESCO	0.95	0-1.00	0.52	0.65
Ground water Revap coefficient	GW_REVAP	0.02	0.02-0.20	0.15	0.02
Channel hydraulic conductivity	CH_K2	20.0	-0.01-150	10.00	0.00
Temperature lapse rate	TLAPS	0.00	0-1.00	0.70	1.00
Soil available water capacity	SOL_AWC	0.00	-0.04-0.04	0.04	0.02
Infiltration method used	Cure Number				
ET method used	Priestley-Taylor				

Table 3. Evaluation statistics for the observed vs. simulated monthly streamflow at Goeangwan and Jindong stations.

Stream flow compared between observed with simulated data	Calibration period (1995-2004)		Validation period (2005-2009)	
	ENS	R ²	ENS	R ²
Goeangwan station	0.81	0.92	0.86	0.94
Jindong station	0.78	0.90	0.83	0.92

sub2, sub4, sub6, and sub8. Therefore, the result shows the annual mean soil water simulated by the SWAT model for different periods of climate change under SRES A2 in the future. In general, results indicated annual soil water increased for all future periods, with soil water content increasing more for the period of 2040-2069 than other periods, and little decreasing tendency for the period of 2070-2099 at nine sub basins in the study area (Figure 3). In these results showed that, the annual mean soil water under the influence of climate change increased most by +1.30% for sub5 and least for +1.02% at sub6. For SR2 and SR3 compared with SR1, the highest increase in soil water content was +3.52% at sub3 and +1.95% at sub8, while the lowest change in soil water content was +1.16% and +0.85% at sub7, respectively. The calculated results revealed that the effect of climate change on soil water is not only its impact on temporal, but also on spatial, characteristics at each site in the basin.

Figure 4 shows the changes in monthly average values of soil water content. There are quite different characteristics for the changes for monthly soil water in the future. In fact, the soil water content has clearly increasing trends in the months of June, July and August, but it shows decreasing tendency in the months of April, May and November at all or most of the sub basins. In particular, at sub1, the mean soil water from June to August increased by +3.28, +4.52, and +4.07% for the period of 2010-2039; +3.38, +4.81, and +4.07% for the 2040-2069 period; and +3.20, +4.05, and +3.76% for the

2070-2099 period. In contrast, mean monthly soil water in April, May and November decreased by -2.04, -2.93 and -2.11%; -2.23, -3.12 and -2.58%; and -1.61, -2.82 and -2.77%. The changes in soil water for the other sub basins are shown in Figure 4. The soil water storage results indicated density of the maximum values that appeared in July and the highest value reached was +10.67% at sub4. However, the reduction mainly appears in May, but the lowest value is -5.28% in November at sub5 in the 2040-2069 period. In the other months, these changes are not so much. On the other hand, the effect of climate change on soil water is not only temporal but also spatial. In particular, the soil water content is high in the East-North as at sub1, sub2, and sub3 (100.42, 106.70 and 95.93 mm annually) respectively for the periods 1980-2009 and 2070-2099. But in the periods of 2010-2039 and 2040-2069, the soil water content is high both for East-North and East-South at sub1, sub2, sub3, sub8, and sub9. The determination of spatial change helps in understanding water supply capacity and future crop productivity in water-resource management strategies to adapt for agriculture development in each sub-basin. In conclusion, the above results indicate a soil water shortage resulting from reductions in April, May and November in the future. These results help to determine that the water resource supply may be more vulnerable to crop water demand in the region. Moreover, these impacts can include more extreme drought events in two months at the end of spring and the first month of the winter season.

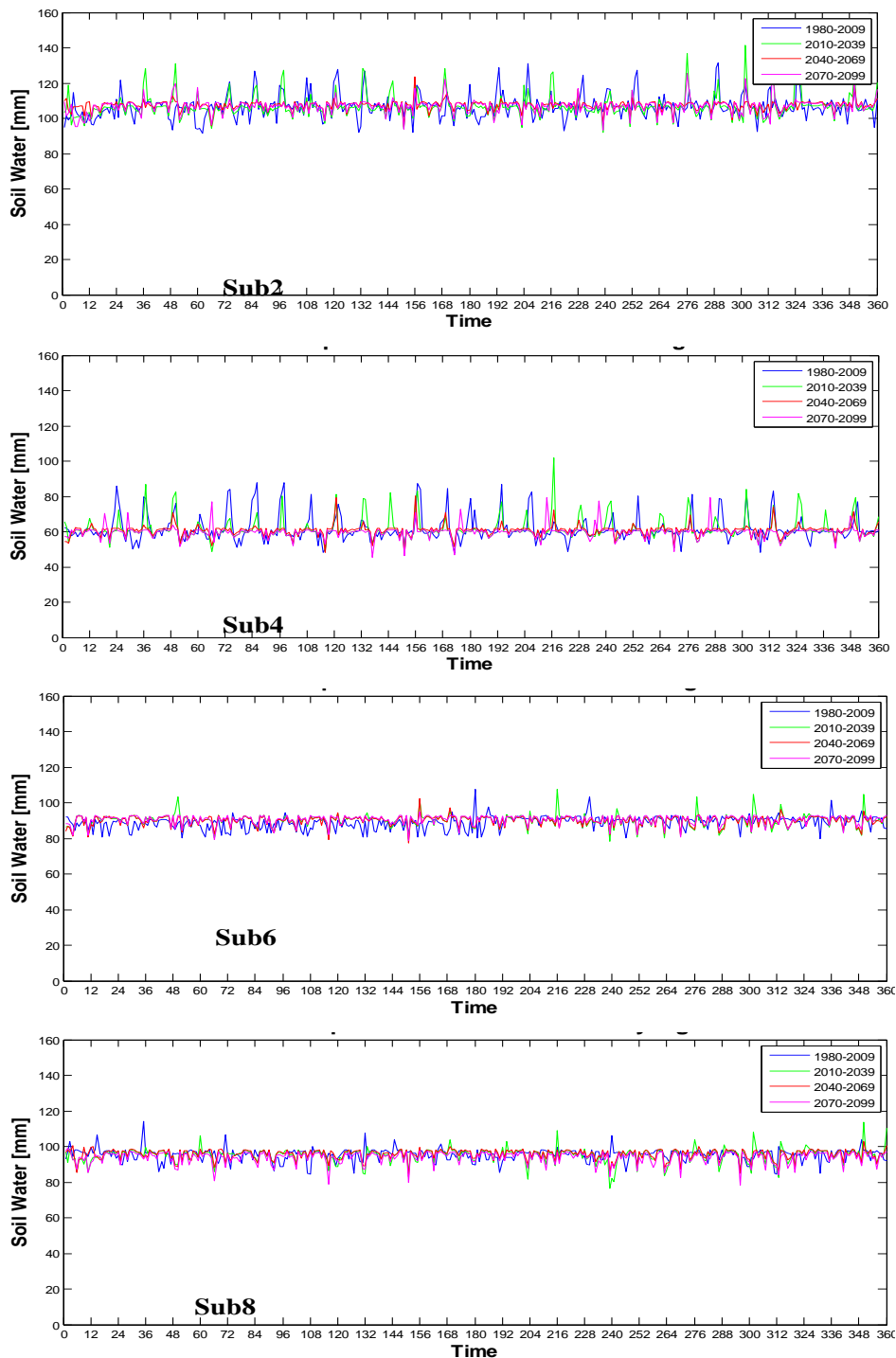

Figure 3. Impact of climate change on annual mean soil water at nine sub-basins.

Effect of climate change on drought occurrence

Figure 5 illustrates SPI in current and future periods and Figure 6 shows the monthly mean SPI values for drought for nine sub-basins in the study area. The results clearly indicated SPI values most sharply reducing in May, then

a gradually increasing tendency in June, July and August for most of the periods in the sub-basins, except in the period of 2070-2099. Result shows that the lowest SPI values occurred in April, May and November at all sub-basins (Figure 6). Moreover, the extreme drought level showed that that is mainly in May with four sub basins for

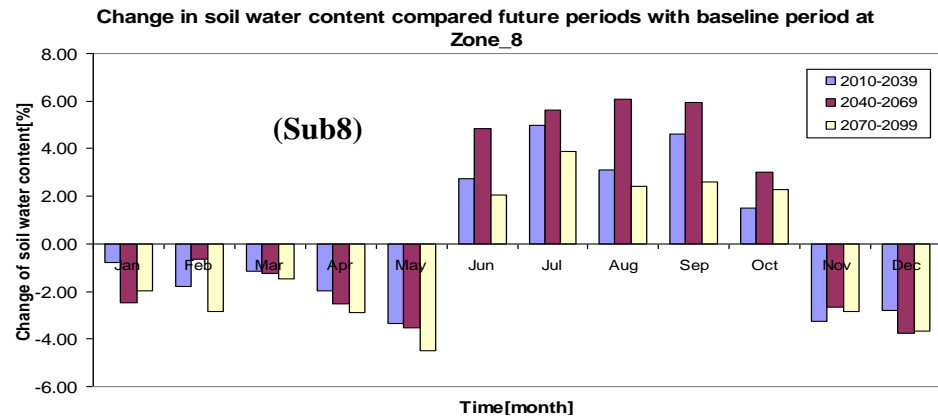
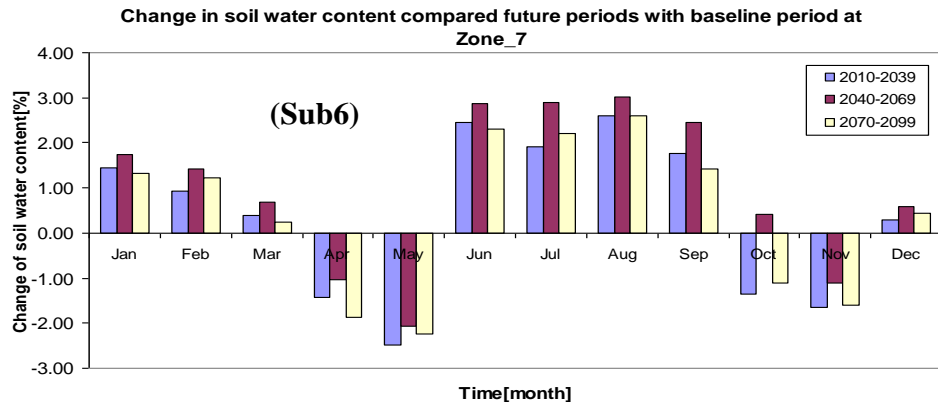
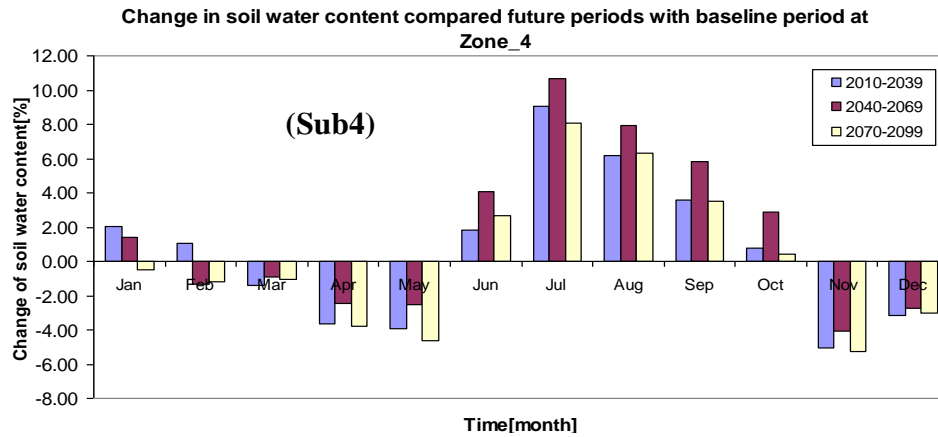
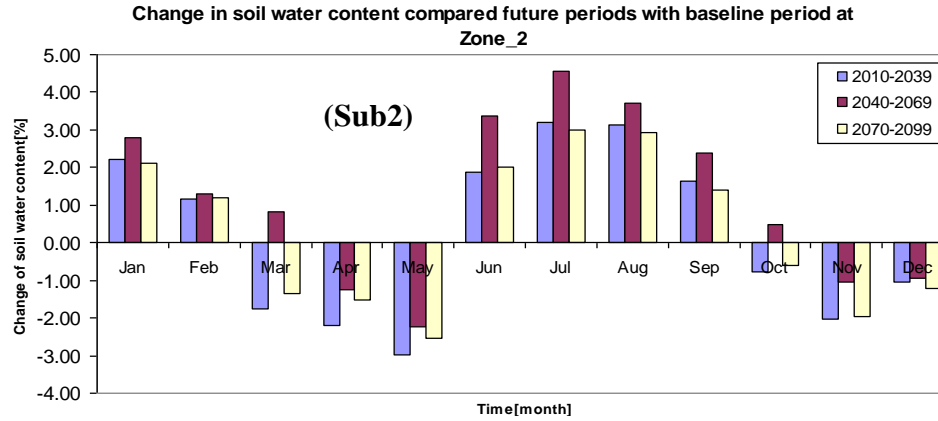

Figure 4. Effect of climate change on average month soil water at all sub basins.

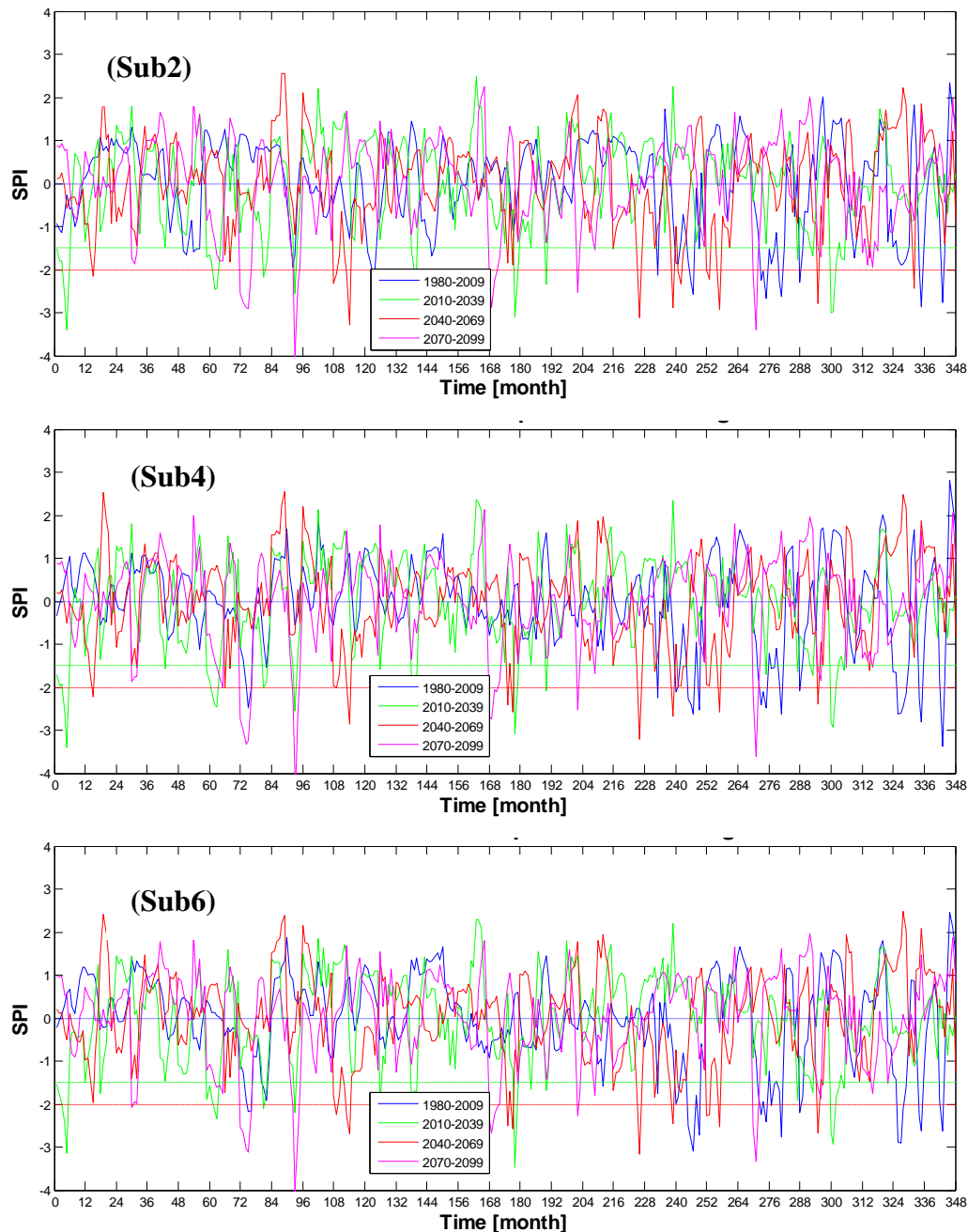

Figure 5. Illustrate SPI in current and future periods at nine sub-basins.

the period of 1980-2009; at five sub-basins for the period of 2010-2039; at three sub-basins for the period of 2040-2069; and at five sub-basins for the period of 2070-2099, and the lowest value of SPI is -2.32 (extreme drought level) in May at sub5 in the period of 2010-2039. Other months are less than May as shown in Figure 6. The extreme drought level occurred not so much in April and November, but the severe drought level happened with increasing intensity in these two months. Specifically, the

severe drought level appeared at six sub-basins in April and at seven sub-basins in November in 1980-2009; in the period of 2010-2039 it appeared at five sub-basins in April and at six sub-basins in November; at four sub-basins in April and at six sub-basins in November in the 2040-2069 period; and in particular, the highest intensity of severe drought level occurred at nine sub-basins in April and seven sub-basins in November in the 2070-2099 period. Severe drought level in April is unchanged

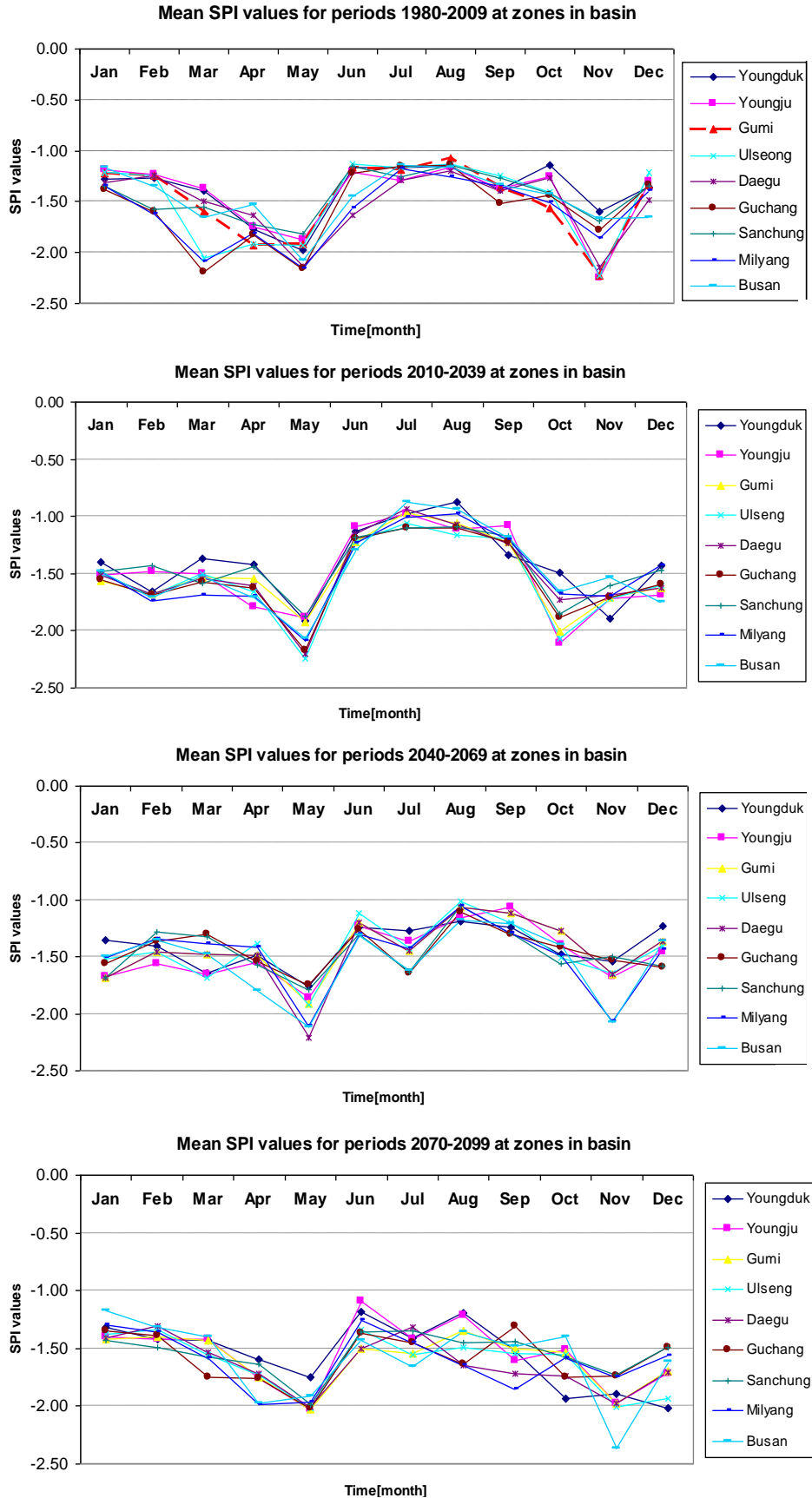

Figure 6. Mean SPI values for drought appearance for periods at sub basins.

in 2010-2039 and 2040-2069 but then sharply increasing in the 2070-2099 period, and appears in April and May which can result in drought in the spring season in the future. In addition, the results indicate that the annual drought occurrence levels have an increasing trend from West through South and gradually reducing from North to East.

DISCUSSION AND CONCLUSIONS

Since drought occurrences are not defined using absolute quantities of soil water as above-mentioned, they are defined using a combination of a hydrology model and Standardized Precipitation Index in order to achieve the purpose of this study. This study analyzed the occurrence of drought in the future under the effect of climate changes and greenhouse gas emissions under scenario A2. Based on the results of the study, the soil water showed large changes in months/seasons. The soil water content in summer is clearly distinguished from the form of soil water content in other seasons (Figure 4). Results determined the soil water content from hydrology model output for climate data, which is similar in duration and density to SPI values from using the Standardized Precipitation Index at each specific sub-basin in the study area. However, there are differences in drought duration and intensity in some sub-basins, but the differences in the changes in both soil water content and SPI in different periods are not very big. The hydrology model method applied in this study did not have any big problem expressing the behavior of soil water content combined with the Standardized Precipitation Index tool, to assess drought occurrence in the study area. Reference soil water content in sub-basins and by month were calculated and the effect of climate change on future occurrence of droughts was evaluated by using the reference soil water content. Based on the results, it was identified that, the most serious increases of soil water content and SPI value in the months of June, July and August were predicted at several sites in the basin. In contrast, the decreasing trend is more complicated than the increase in soil water content and SPI value, as the results showed reductions at sites were not only remarkable in spring (April and May) but also in the end of autumn and beginning of winter (November and December). The results determined that the lowest SPI values occurred in May and the lowest value is -2.32 at sub5 in the period of 2010-2039, and the 2070-2099 period had the highest intensity of extreme drought in five sub-basins with other periods less intense in extreme and severe drought. Extreme drought occurred not so much in April and November but severe drought happened with increasing intensity in these two months.

In summary, this study attempts to quantify the climate change impact on soil water availability by a water balance simulation modelling approach of the SWAT

model and SPI values for the study of Nakdong basin in Korea. This study used a number of models for impact assessment to confer valuable outputs and at the same time introduced a number of uncertainties. For this study, two different tools were used, which give different model outputs. Results indicated that there will be high monthly variation of soil water compared to annual, as the average of simulated annual mean soil water compared between 2070-2099 and 1980-2009 has the highest increase of +1.30% in sub5 and the lowest change of +1.02% at sub6 while 2010-2039 and 2040-2069 compared with 1980-2009 reached the highest increases in soil water content of +3.52% at sub3 and +1.95% at sub8, while the soil water content had its lowest change of +1.16% at sub7 and +0.85% at sub7, respectively, while relative to the base periods the soil water in June, July, and August increased soil water storage results indicate density of maximum values in July and higher increases in the period of 2040-2069, with the highest value reached of +10.67% in sub4. In contrast, the soil water in April, May and November are strongly reduced, mainly in May, but the lowest value of -5.28% is appeared in November in sub5 of the 2040-2069 periods. In conclusion, the results showed climate change effects on future drought levels and it also revealed that its impact is not only temporal variation, but also spatial variation on the drought levels in study region. Results indicated that the severe droughts seem to appear in April, May and November. The results suggest that the drought occurrence levels have a trend of increased severity from the North to the South and gradually reduced from the East to the West in May, but then the drought severity increased in the middle of basin with the trend from the South to the North in November. The study suggests that the drought occurrence is not only evaluated in years but also evaluate in seasons/months in the future. These impacts can be more extreme events of drought in two months in spring and the end of the autumn season and it can help to determine that the water resource supply is more vulnerable on water demand of crop in the study region. Finally, this study is expected to be appropriately applicable to the evaluation of the effects of extreme hydrologic events, and this paper can provide useful values for sustainable water-resource management strategies and policy in agricultural basins in the future.

RECOMMENDATIONS

The soil water content can be influenced not only by climate change but also land use change. Therefore, effective assessment of soil water content should be considered in model simulations of both climate change and land use change scenarios in the future. In addition, the climate change projections can use a GCM model with SRES scenarios such as A2, B1A and B1. SPI

values using Standard Precipitation Index should be calculated for different time scales for effective assessment of climate change in combination with soil water content by a hydrology model.

Conflict of Interest

The authors have not declared any conflict of interest.

ACKNOWLEDGEMENTS

The author of this paper would like to thank the Korea Meteorological Administration (KMA) and Water Management Information System (WAMIS), Korea, for providing all the data for this study.

REFERENCES

Arnold JG, Srinivasan R, Muttiah RS, Williams JR (1998). Large area hydrologic modelling and assessment Part 1: Model development. *American J. Water Resour. Assoc.* 34(1):73-89.

Bae DH, Jung IW, Lettenmaier DP (2011). Hydrologic uncertainties in climate change from IPCC AR4 GCM simulations of the Chungju Basin. *Korean J. Hydrol.* 401:90-105.

Byun HR (1996). On the atmospheric circulation caused drought in Korea. *Korean J. Meteorol. Soc.* 32:455-469.

Gleick PH (1993). *Water in Crisis: A Guide to the World's Fresh Water Resources.* Oxford University Press, New York, NY.

Han YH, Byun HR (1994). On the existence of seasonal drought in the Korean Peninsula. *Korean J. Meteorol. Soc.* 30:457-467.

Heim RR (2002). A review of twentieth-century drought indices used in the United States. *American J. Meteorol. Soc.* 83(8):1149-1166.

IPCC (2007). *Climate Change 2007: The Physical Science Basis. Contribution of WG I to the fourth assessment report of the Intergovernmental Panel on Climate Change.* Cambridge University Press: Cambridge. Available at <http://ipcc-wg1.ucar.edu/wg1/wg1-report.html>.

Karavitis CA, Alexandris S, Tsesmelis DE, Athanasopoulos G (2011). Application of the Standardized Precipitation Index (SPI) in Greece. *American J. Water Resour. Assoc.* 3:787-805.

Kyung M, Kim S, Kim B, Kim H (2007). Construction of hydrological drought severity-area-duration curves using cluster analysis. *Korean J. Soc. Civil Eng.* 27:267-276.

Le Roy Ladurie E (1971). *Times of feast, times of famine: A history of climate since the Year 1000* (Barbara Bray, Trans.). Doubleday, New York, NY.

McKee TB, Doesken NJ, Kleist J (1993). The relationship of drought frequency and duration to time scales, in *Proceedings of the 8th Conference on Applied Climatology*, Anaheim, California, USA, pp.179-184.

Quan and Kim 251

McKee TB, Doesken NJ, Kleist J (1995). Drought monitoring with multiple time scales, in *Preprints, 9th Conference on Applied Climatology*, Dallas, TX, USA, pp. 233-236.

Neitsch SL, Arnold JG, Kiniry JR, Srinivasan R, Williams JR (2005a). *Soil and Water Assessment Tool Theoretical Documentation*, version 2005. Temple, TX: Grassland, Soil and Water Research Laboratory, Agricultural Research Service.

Neitsch SL, Arnold JG, Kiniry JR, Srinivasan R, Williams JR (2005b). *Soil and water assessment tool input/output file documentation*, version 2005. Temple, Texas: Grassland, Soil and Water Research Laboratory, Agricultural Research Service. Available at: www.brc.tamus.edu/swat/doc.html. Accessed 1 November 2006. www.brc.tamus.edu/swat/doc.html. Accessed 1 November 2006.

Park S, Feddema JJ, Egbert SL (2005). MODIS land surface temperature composite data and their relationships with climatic water budget factors in the central Great Plains. *Int. J. Remote Sens.* 26(6):1127-1144.

Santhi C, Arnold JG, Williams, JR, Dugas WA, Srinivasan R, Hauck LM (2001). Validation of the SWAT model on a large river basin with point and nonpoint sources. *Am. J. Water Resour. Assoc.* 37(5):1169-1188.

Wilhite DA, Glantz MH (1985) Understanding the drought phenomenon: The role of definitions. *Water International.* 10:111-120.

Witt JL (1997). *National Mitigation Strategy: Partnerships for Building Safer Communities.* Federal Emergency Management Agency.

Arnold JG, Srinivasan R, Muttiah RS, Williams JR (1998). Large area hydrologic modelling and assessment Part 1: Model development. *American J. Water Resour. Assoc.* 34(1):73-89.

<http://dx.doi.org/10.1111/j.1752-1688.1998.tb05961.x>

Bae DH, Jung IW, Lettenmaier DP (2011). Hydrologic uncertainties in climate change from IPCC AR4 GCM simulations of the Chungju Basin. *Korean J. Hydrol.* 401:90-105. <http://dx.doi.org/10.1016/j.jhydrol.2011.02.012>

Byun HR (1996). On the atmospheric circulation caused drought in Korea. *Korean J. Meteorol. Soc.* 32:455-469.

Gleick PH (1993). *Water in Crisis: A Guide to the World's Fresh Water Resources.* Oxford University Press, New York, NY. PMID:8409181

Han YH, Byun HR (1994). On the existence of seasonal drought in the Korean Peninsula. *Korean J. Meteorol. Soc.* 30:457-467.

Heim RR (2002). A review of twentieth-century drought indices used in the United States. *American J. Meteorol. Soc.* 83(8):1149-1166.

IPCC (2007). *Climate Change 2007: The Physical Science Basis. Contribution of WG I to the fourth assessment report of the Intergovernmental Panel on Climate Change.* Cambridge University Press: Cambridge. Available at <http://ipcc-wg1.ucar.edu/wg1/wg1-report.html>.

Karavitis CA, Alexandris S, Tsesmelis DE, Athanasopoulos G (2011). Application of the Standardized Precipitation Index (SPI) in Greece. *American J. Water Resour. Assoc.* 3:787-805.

- Kyung M, Kim S, Kim B, Kim H (2007). Construction of hydrological drought severity-area-duration curves using cluster analysis. *Korean J. Soc. Civil Eng.* 27:267-276.
- Le Roy Ladurie E (1971). *Times of feast, times of famine: A history of climate since the Year 1000* (Barbara Bray, Trans.). Doubleday, New York, NY.
- McKee TB, Doesken NJ, Kleist J (1993). The relationship of drought frequency and duration to time scales, in *Proceedings of the 8th Conference on Applied Climatology*, Anaheim, California, USA, pp.179-184.
- McKee TB, Doesken NJ, Kleist J (1995). Drought monitoring with multiple time scales, in *Preprints, 9th Conference on Applied Climatology*, Dallas, TX, USA. pp. 233-236.
- Neitsch SL, Arnold JG, Kiniry JR, Srinivasan R, Williams JR (2005a). *Soil and Water Assessment Tool Theoretical Documentation*, version 2005. Temple, TX: Grassland, Soil and Water Research Laboratory, Agricultural Research Service.
- Neitsch SL, Arnold JG, Kiniry JR, Srinivasan R, Williams JR (2005b). *Soil and water assessment tool input/output file documentation*, version 2005. Temple, Texas: Grassland, Soil and Water Research Laboratory, Agricultural Research Service. Available at: www.brc.tamus.edu/swat/doc.html. Accessed 1 November 2006.
- Park S, Feddema JJ, Egbert SL (2005). MODIS land surface temperature composite data and their relationships with climatic water budget factors in the central Great Plains. *Int. J. Remote Sens.* 26(6):1127-1144. <http://dx.doi.org/10.1080/01431160512331326503>
- Santhi C, Arnold JG, Williams JR, Dugas WA, Srinivasan R, Hauck LM (2001). Validation of the SWAT model on a large river basin with point and nonpoint sources. *Am. J. Water Resour. Assoc.* 37(5):1169-1188. <http://dx.doi.org/10.1111/j.1752-1688.2001.tb03630.x>
- Wilhite DA, Glantz MH (1985) Understanding the drought phenomenon: The role of definitions. *Water International.* 10:111-120. <http://dx.doi.org/10.1080/02508068508686328>
- Witt JL (1997). *National Mitigation Strategy: Partnerships for Building Safer Communities*. Federal Emergency Management Agency.



International Journal of Water Resources and Environmental Engineering

- *Journal of Petroleum and Gas Engineering*
- *Journal of Mechanical Engineering Research*
- *Journal of Chemical Engineering and Materials Science*
- *Journal of Engineering and Computer Innovations*
- *Journal of Engineering and Technology Research*
- *Journal of Petroleum Technology and Alternative Fuels*

academicJournals